

1. Applicable documents



NOTE:

The following documents are available to download on our website. Only the documents currently available on the website are valid

- Catalogue
- Drawings, performance data, information about accessory parts etc. General
- Technical Data (Data sheets)
- Terms and Conditions (GTCs), Includes warranty information

2. Proper use



NOTE:

The gripper should only be used in its original state with its original accessories, with no unauthorised changes and within the scope of its defined parameters for use. Zimmer GmbH accepts no liability for any damage caused by improper use

The gripper is designed for operation with compressed air only. It is not suited to operation with other media such as liquids or other gases. The gripper is used as defined under „Proper use“ in closed rooms to temporarily grip, handle and hold parts. It is not suitable for clamping workpieces during a machining process or for direct contact with perishable goods.

3. Function

One sided pressure admission enables the pneumatic piston ① in horizontal movement .



The return movement is depressurised by means of springs ②,

A gripper jaw ③ is powered directly by the piston, The second gripper jaw is moved synchronously by connecting rack and pinion ④.

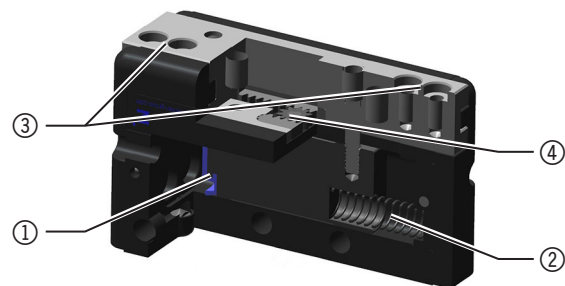
On delivery state, the gripper is setting on the mode NO (normaly open), external gripping



The gripper may be operated in two modes:

NO: (normaly open)  , Gripper direction:  , external gripping

condition of delivery
The basic position of the gripper is opened in pressureless state..
When pressure admission of the gripper the jaws move inwards.

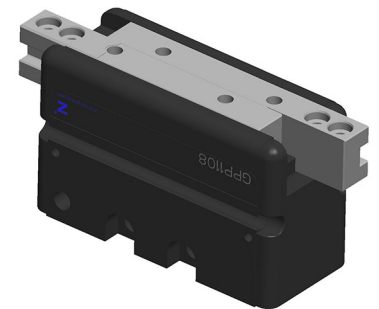



NC : (normaly close) :  , Gripper direction  , internal gripping

The basic position of the gripper is closed in pressureless state.
When pressure admission of the gripper the jaws move outwards.



Depending on the chosen mode of operation, the gripper jaws must be mounted on the top jaws.

Example NC  : Gripper direction  , Gripper jaws outward-looking, internal gripping

Example NO  : Gripper direction  , Gripper jaws introversive, external gripping

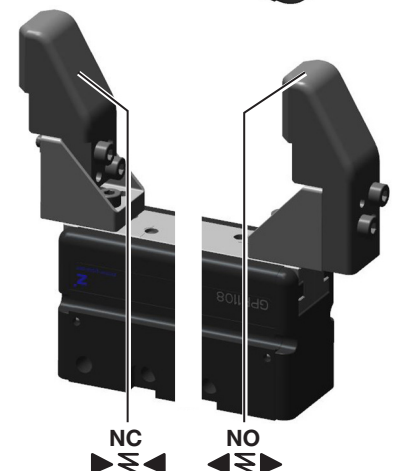

CAUTION:

The built-in springs are for returning the piston to the basic position when exhaust. This basic position must be not used for gripping.
no assurance of gripping force!

4. Mounting

41. Mounting accessories

- ▶ Mounting the pneumatic connection ⑤ on the lateral or bottom side

Note:

- unused connection close with screw
- use suitable sealant
- ▶ mount the cylindrical pins according direction
 - ⑥: Mounting on the lateral side
 - ⑦: Mounting from bottom
- ▶ Brake out the top jaws ⑧ and center sleeve ⑨ on the injection-molded. Parts with a suitable tools deburring.
- ▶ put in the centering sleeves in the gripper jaws. For the insertion of the centering sleeves, a greater force can be necessary
 - > **apply any mechanical force**
- ▶ top jaws mounted with Mounting screws ⑩

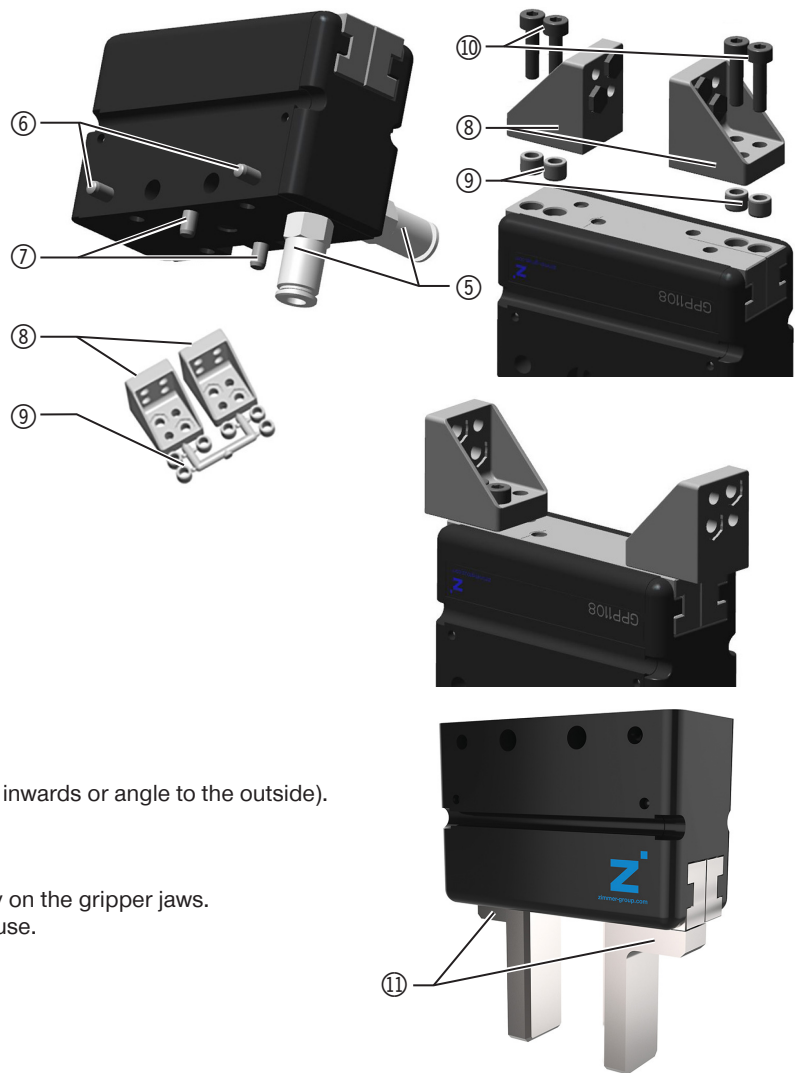

The parts ⑥, ⑦, ⑧, ⑨, ⑩ are content of delivery.

The top jaws can be mounted in two directions . (angle inwards or angle to the outside).

It is also possible to mount own gripper jaws ⑪ directly on the gripper jaws. The centering sleeves ⑨ and mounting screws ⑩ are use.

 **CAUTION:**
The assembly of jaws, with lateral force introduction into the plane of movement of the jaws is not permitted.

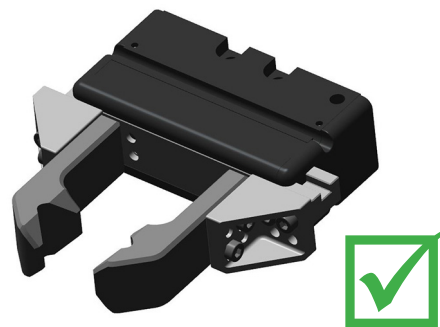

4.2. Mounting the connecting construction

The gripper can be mounted in 3 different versions of a connecting structure:

- ▶ from bottom with 4 mounting screws M4 on the adapter plate AP1100
- ▶ The adapter plate is available as an accessory



- ▶ laterally from the front with 2 mounting screws M4 on the adapter plate AP1100
- ▶ The adapter plate is available as an accessory



- ▶ laterally from behind with 2 mounting screws M5 on its own connecting construction
- ▶ This type of installation is not possible with the adapter plate AP1100!



4.3. Mounting the magnetic field sensors

For the assembly of magnetic field sensors ⑫ corresponding guides ⑬ on both sides are available.

It can only be used magnetic field sensors for position sensing. A sensor on each side of the gripper.

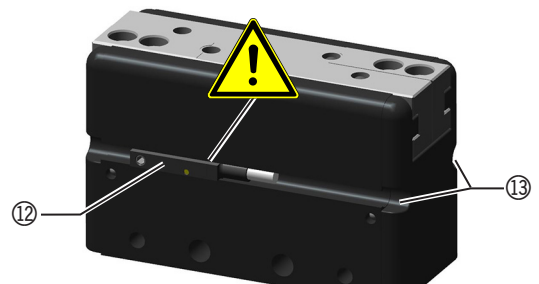

CAUTION:

The magnetic field sensors tower over the housing of the gripper in the assembled State. The connecting construction must be adapted accordingly.

4.4. Modification the operating mode

On delivery state, the gripper is setting on the mode NO (normally open) (pressureless, spring-loaded, opening)
 (Gripper direction: , external gripping)

For a modification to the operating mode NC (normaly close) (pressureless, spring-loaded, opening)
 (Gripper direction , internal gripping) following steps are necessary:

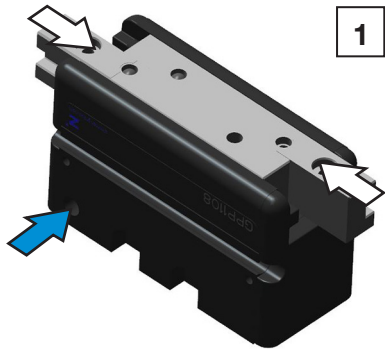

1 ► grippers pressurize > gripper jaws drive inwards (pic 1)

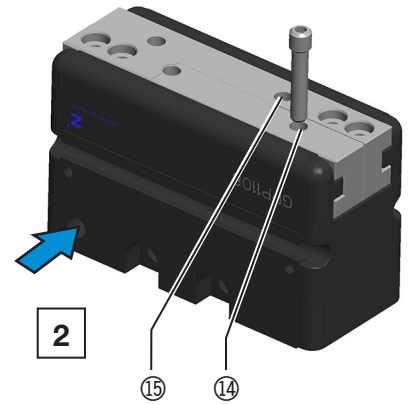

► unscrew grub screw ⑮ and carrier ⑭ (pic 2)

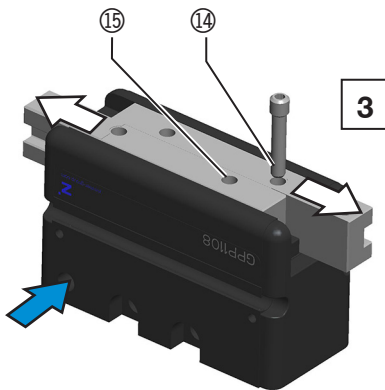

3 ► push apart gripper jaws manually (pic 3)
 ► screw the grub screw ⑮ and carrier ⑭ in the opposite position to previous use..

Note:

- When installing the carrier ⑭, the gripper jaws may be moved possible against each other
- Screw the grub screw ⑮ and carrier ⑭, until a resistance is felt.

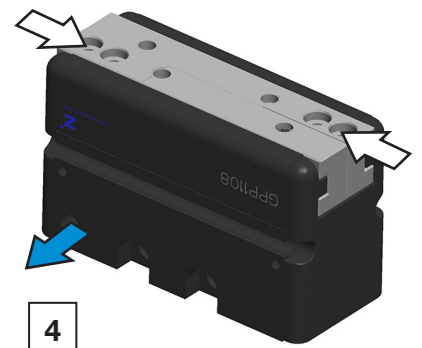

► **Gripper de-aerate** > if the carrier is installed correctly, the gripper jaws are now moving into the new basic position NC (normaly close) (pic 4)

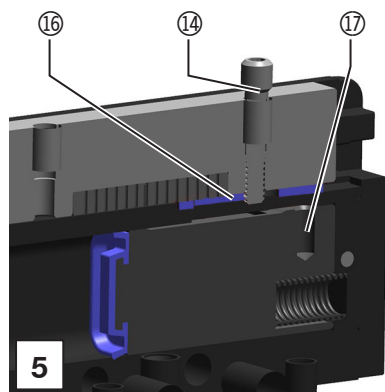

Note:

- With grippers of size in 1116 is located at the gripper jaws a sealing plate ⑯.
- This seal plate can prevent that the carrier ⑭ can be screwed in the hole ⑰.
- In this case, the carrier must be lightly pressed with your finger. The gripper jaws must be moved so far until the carrier locks in the hole.
- Then the carrier can be screwed. (pic 5)

4.5. Deconstruction of the operating mode in the delivery State NO (normaly open)

For a deconstruction to the operating mode NO (normaly open) (pressureless, spring-loaded, opening) (Gripper direction: || , external gripping), following steps are necessary:

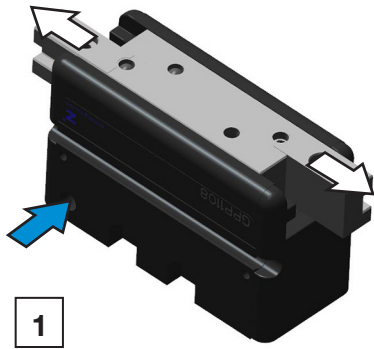

▶ **grippers pressurize** > gripper jaws drive outwards (pic 1)

▶ unscrew grub screw ⑮ and carrier ⑭ (pic 2)

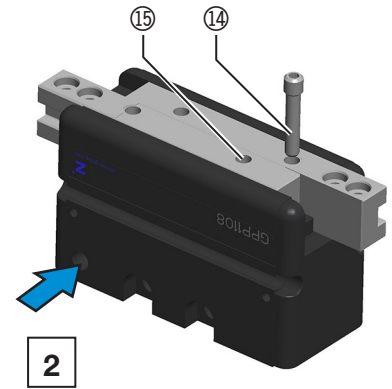

▶ push together gripper jaws manually (pic 3)
▶ screw the grub screw ⑮ and carrier ⑭ in the opposite position to previous use..

Note:

- When installing the carrier ⑭, the gripper jaws may be moved possible against each other
- Screw the grub screw ⑮ and carrier ⑭, until a resistance is felt.

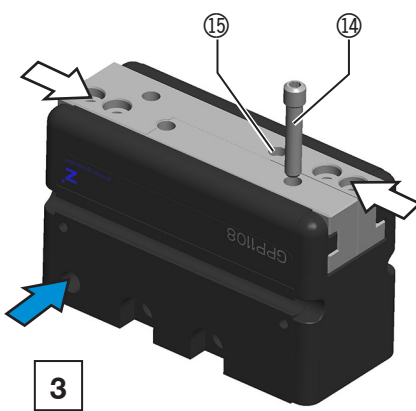

▶ **Gripper de-aerate** > if the carrier is installed correctly, the gripper jaws are now moving into the delivery state position NO (normaly open) (pic 4)

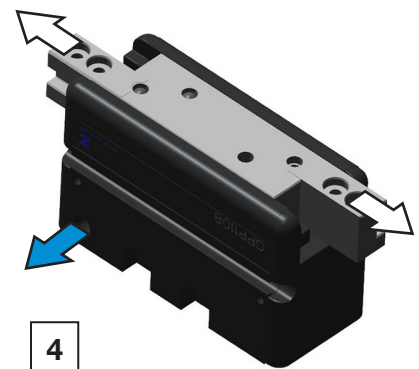

5. Live cycle

Maintenance-free operation of the gripper is guaranteed for up to 2 million cycles.

The live cycle may shorten under the following circumstances:

- Operation with compressed air that does not comply with DIN ISO 8573-1 quality class 4
- Dirty environment
- Improper use and use that does not comply with the performance data

6. Declaration of incorporation in terms of the EC Directive 2006/42/EC on Machinery (Annex II 1 B)

Name and address of the manufacturer: Zimmer GmbH
 Im Salmenkopf 5
 77866 Rheinau

We hereby declare that the incomplete machines described below

Product destination: Gripper pneumatic

Type destination: **GPP1**

satisfy the following basic requirements of the Machinery Directive 2006/42/EC

Nr.1.1.2., Nr.1.1.3., Nr.1.1.5., Nr.1.3.2., Nr.1.3.4., Nr.1.3.7., Nr.1.5.3., Nr.1.5.4., Nr.1.5.8., Nr.1.6.4., Nr.1.7.1., Nr.1.7.4.

We also declare that the special technical documents were produced in accordance with Annex VII Part B of this Directive. We undertake to provide the market supervisory bodies with electronic versions of the incomplete machine's special documents via our documentation department should they have reason to request them.

The incomplete machine may only be commissioned if it has been ascertained, if applicable, that the machine or system in which the incomplete machine is to be installed satisfies the requirements of Directive 2006/42/EC on Machinery and an EC declaration of conformity has been drawn up in accordance with Annex II 1 A.

Authorised representative for the compilation of the relevant technical documents



Kurt Ross	See manufacturer's address First	Rheinau, 20.11.2015	Martin Zimmer
Surname	Adress	(Place and date)	(legally binding signature) Managing director